

**INITIAL DATA REQUIRED WHEN ORDERING WHEELS FOR INDUSTRIAL TRUCKS**

**ИЗХОДНИ ДАННИ, НЕОБХОДИМИ ЗА ПОРЪЧКА НА ИНДУСТРИАЛНИ КОЛЕЛА**

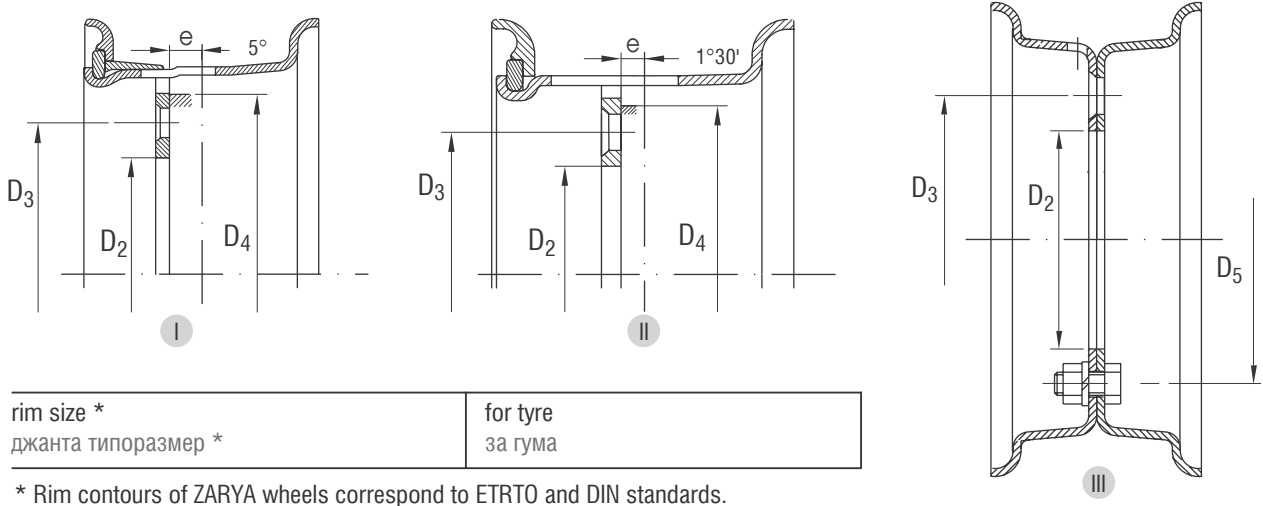

rim size * джанта типоразмер *	for tyre за гума
-----------------------------------	---------------------

\* Rim contours of ZARYA wheels correspond to ETRTO and DIN standards.

wheel type колецо тип	ZARYA draw No чертежен номер ЗАРЯ	customer part No означение на клиента
<input type="checkbox"/> I <input type="checkbox"/> II <input type="checkbox"/> III		

divided wheel - type III сдвояване на коелата - тип III		
D <sub>5</sub>	bolt, M болт, М	No of holes брой

offset несиметричност	disc type ВИД ДИСК	<input type="checkbox"/> 1 <input type="checkbox"/> 2
--------------------------	-----------------------	-------------------------------------------------------

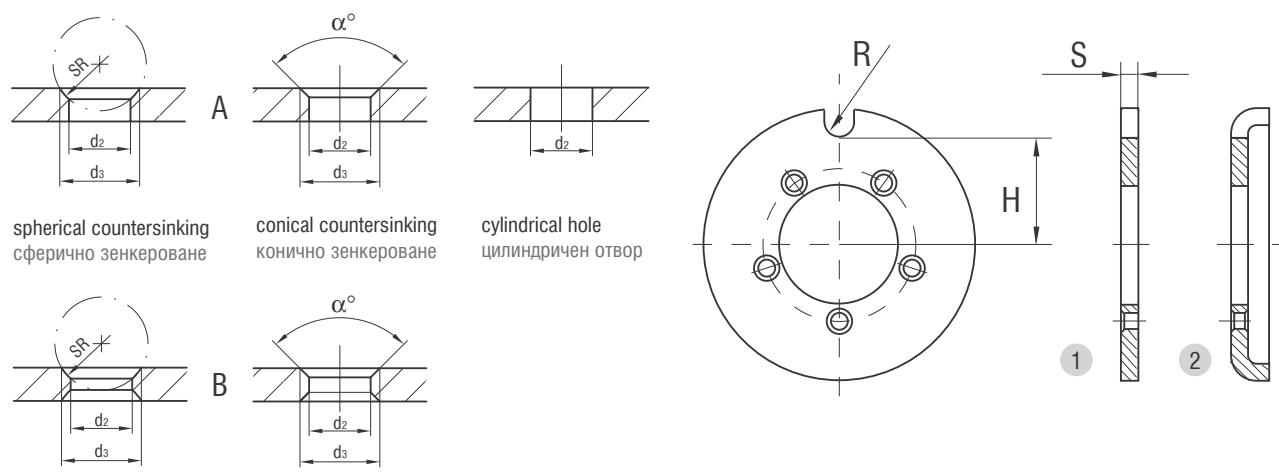

stud holes / отвори						
type ВИД	No of holes брой	D <sub>3</sub>	D <sub>2</sub> <sup>+...</sup>	d <sub>2</sub> <sup>+...</sup>	d <sub>3</sub> <sup>+...</sup>	SR (α°)
<input type="checkbox"/> A <input type="checkbox"/> B <input type="checkbox"/> cylindrical hole цилиндр. отв.						

disc / диск			
D <sub>4</sub> <sup>+...</sup>	S <sup>±...</sup>	R	H

surface treatment / повърхностна обработка

additional requirements / допълнителни изисквания